

# Product Information



BRETFORD MANUFACTURING, INC.  
11000 Seymour Avenue  
Franklin Park, Illinois 60131 USA

Phone: 847.678.2545  
Toll-Free Phone: 800.521.9614  
Fax: 847.678.0852  
Toll-Free Fax: 800.343.1779  
www.bretford.com

## EC2741-BK & EC2741FF-BK LCD Projector Table/Mobile Teachers Workstation



EC2741FF-BK shown

### FEATURES & BENEFITS

- EC2741FF-BK comes with surge protected 4-outlet electrical assembly with on/off switch and 20' cord
- Sturdy workstation supports your computer and LCD Projector
- Ideal for any presentation by quickly adjusting to stand up or sit down applications
- Adjustable CPU Tower holder mounts on the left or right side
- Worksurface adjusts from 27" - 41" H
- Modesty panel features an integrated cord management bin
- 4" Quiet-Glide casters, two are locking
- Durable all-steel construction

### DIMENSIONS

Overall:	37" W x 22½" D x 27-41" H
CPU Holder:	Adjusts from 6½" - 11¾" W
Cord Bin/Modesty Panel:	1½" D x 4" H
Carton Pack:	20" W x 25" D x 39" H

### COLOR/FINISH AND UPC CODES

- EC2741-BK: Black (-BK) powder paint - UPC 96633 17802
- EC2741FF-BK: Black (-BK) powder paint - UPC 96633 17803

# Product Specifications

## EC2741-BK & EC2741FF-BK LCD PROJECTOR TABLE/MOBILE TEACHERS WORKSTATION

Bretford's EC2741 LCD Projector Table/Mobile Teachers Workstation features an adjustable worksurface (27" - 41" H), perfect for both stand up or sit down applications. Adjustable CPU holder mounts to left or right side of workstation. Modesty panel and integrated cord management bin. Durable all-steel construction. 4" "Quiet Glide" casters, two locking. Finished in Black powder paint.

## UPC CODES

EC2741-BK: 966331 7802

EC2741FF-BK: 966331 7803

## WEIGHT AND FREIGHT CLASS

EC2741-BK: 73 lbs

EC2741FF-BK: 75 lbs

Ships UPS in one carton pack ready to assemble

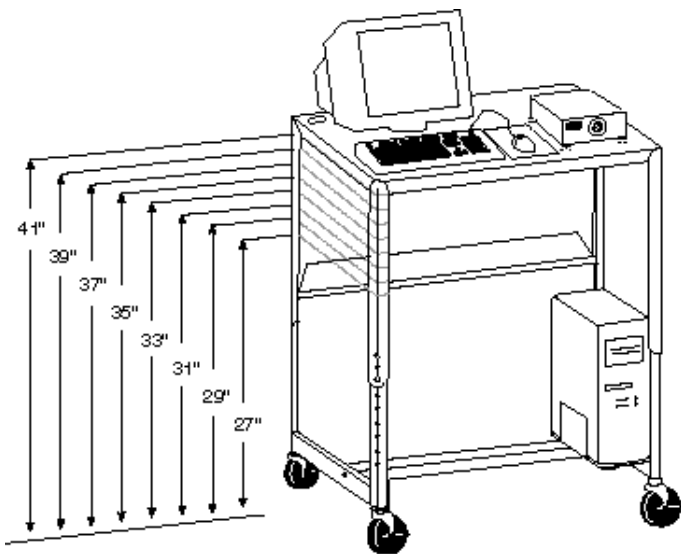

## Suggested Specifications

EC2741-BK Adjustable LCD Projector Table has one (1) 20-gauge steel shelf, 37" W x 22½" D. Shelf is press formed so that a ⅛" lip borders the top surface on all four sides. Surface has two grommets in both the left and right back corners. Four (4) 14-gauge steel legs, 20¼" in length, are welded to the shelf at each corner. Each leg has four (4) ¼" diameter holds down the center so it accepts a ¼" 20 machine screw. The holes are spaced 2" apart to permit table adjustments of 27", 29", 31", 33", 35", 37", 39" and 41" in height. Table shall have one (1) 20-gauge steel 36" W x 18" H modesty panel that is attached between the rear legs. Modesty panel has an integrated cord management bin which measures 1 ½" D x 4" H. Adjustable projector table has one (1) 14-gauge steel, welded "H" frame assembly. Has one 18-gauge adjustable CPU holder that mounts to the left or right side of the "H" frame base. The CPU holder adjusts from 6 ½" - 11 ½". Four (4) 14-gauge steel legs, 19" in length, are welded to the "H" frame. Each leg has one (1) ¼" diameter hole spaced 2" from the top and in the center so it allows eight (8) height adjustments (as noted above). Arc welded caster socket with a hard plastic caster insert is secured to the legs. Casters are mar-resistant Black hard rubber and are 4" in diameter. Each caster assembly has ball bearing swivel capabilities and steel construction. Two (2) have locking brakes. Model # EC2741FF-BK includes a surge protected 4-outlet electrical assembly with on/off switch and 20' 3-wire cord and two (2) ⅜" diameter machine screws with nuts for attaching unit to the table. Electrical assembly is C-UL and UL listed when attached. Finished in Black powder paint. Table ships ready to assemble (K.D.) in one (1) carton pack.

BRETFORD MANUFACTURING, INC.

11000 Seymour Avenue  
Franklin Park, Illinois 60131 USA  
www.bretford.com

Phone: 847.678.2545  
Fax: 847.678.0852

Toll-Free Fax: 800.343.1779  
Toll-Free Phone: 800.521.9614