

# Product Information



BRETFORD MANUFACTURING, INC.  
11000 Seymour Avenue  
Franklin Park, Illinois 60131 USA

Phone: 847.678.2545  
Toll-Free Phone: 800.521.9614  
Fax: 847.678.0852  
Toll-Free Fax: 800.343.1779  
www.bretford.com

A2642  
Adjustable A/V Cart  
(cart shown finished in Polo)



## FEATURES & BENEFITS

- Quickly and easily adjusts to five heights, from 26" to 42", for fast and easy changes by simply resetting four screws
- Constructed from steel for strength and durability
- Includes ribbed rubber mat to keep equipment from sliding
- Durable shelves allow for storage of supplies and rounded edges provide extra safety
- Ample room on top shelf accommodates monitors up to 20" diagonal or virtually any audio visual equipment
- Black powder paint finish resists everyday wear and tear
- Four-inch "Quiet Glide" casters (two lock) allow for easy movement and safety
- Optional four-outlet electrical unit with built-in cord winder and 20' extension cord allows for easy access to power
- Optional Big Wheel Kit includes two non-swivel and two swivel-locking casters to increase mobility
- Also available in four designer colors to complement any decor: Cardinal(-CD), Polo (-PL), Quartz (-QZ) and Topaz (-TZ)

## DIMENSIONS

- Overall: 24" W x 18" D x 26-42" H
- Shelf: 24" W x 18" D
- Middle to bottom shelf: 15½"
- Carton Pack: 19" W x 22 ½" D x 25" H

## COLOR/FINISH

- Powder paint finish available in:
- Black (BK)
  - Cardinal (CD)
  - Polo (PL)
  - Quartz (QZ)
  - Topaz (TZ)

# Product Specifications

## A2642 ADJUSTABLE EQUIPMENT TABLE

Bretford's open shelf adjustable equipment table, A2642, is potentially five tables in one. Perfect for a variety of applications. Adjusts from a minimum height of 26" up to a maximum height of 42". Recommended for use with up to 20" diagonal screen TV's/Monitors.

## STANDARD EQUIPMENT

24" W x 18" D Shelves (3)  
1" round plastic caster insert (4)  
4" diameter casters (4)  
18" x 24" Rubber Mat  
Plastic bag with all necessary hardware for assembly

## ACCESSORIES

E-Unit Electrical assembly with 2 grounded outlets, 20 ft. grounded extension cord. UL listed when mounted on table.  
ES-Unit Electrical assembly with 3 grounded outlets, 20 ft. grounded extension cord. UL listed when mounted on table.  
044-0025 5" caster pak with 2 locking brakes (can substitute for 4")  
044-0026 Big Wheel Kit  
RM1824 Rubber mat for 18" W x 24" D shelf  
SB Safety Belt 8 ft. in length to hold equipment  
EPS Surge Protected Power Strip

## UPC CODES

A2642 - 96633 10003  
A2642-CD - 96633 14871  
A2642-PL - 96633 14872  
A2642-QZ - 96633 14869  
A2642-TZ - 96633 14870

## WEIGHT AND FREIGHT CLASS

A2642 42 pounds.  
Ships UPS assembled in one carton pack.  
Freight class: 85 UPS.

## CONSTRUCTION

20-gauge steel shelves, arc welded to legs. 14-gauge welded steel legs. Top section 21 $\frac{1}{4}$ " in length. Bottom section 19" in length. "Quiet Glide" caster system with arc welded caster sockets. Color: Black, Cardinal, Polo, Quartz and Topaz. Finish: powder paint. Casters: 4" Black hard rubber (2 with locking brakes). Each caster is load rated to accept 125 pounds.

## SUGGESTED SPECIFICATIONS

Adjustable Table has three (3) 20-gauge steel 18" x 24" shelves. Each shelf is press formed with a  $\frac{1}{4}$ " lip bordering the top surface on all four sides. The top shelf has a 20-gauge steel stiffener electrically welded underneath the surface front to back. A Black rubber 18" x 24" mat is placed on the top shelf. The shelf has two (2)  $\frac{3}{16}$ " diameter holes centered on both the right side and the left side to accept an optional electrical assembly. The table has an adjustable top section that consists of one (1) 20-gauge 18" x 24" shelf with four (4) 14-gauge steel legs 21 $\frac{1}{4}$ " long welded to the shelf at each corner. Each offset leg has two (2)  $\frac{1}{4}$ " diameter holes near the bottom of the section and in the center of the leg that will accept a  $\frac{1}{4}$ -20 machine screw. The holes are spaced 4" apart to permit height adjustments of 26", 30", 34", 38" and 42" when matched to the bottom section of the table. Each offset leg fits over the bottom section of the table and is secured at the desired height by a machine screw. The bottom section of the adjustable table consists of two (2) 20-gauge steel 18" x 24" shelves - one at the top of the section and the other at the bottom. There are four (4) 14-gauge steel 19" legs welded to the shelves at each corner. Each 19" leg has four (4)  $\frac{1}{4}$ " diameter holes down the center of the leg that will accept a  $\frac{1}{4}$ -20 machine screw. Holes are 4" apart to permit table height adjustments (as noted above). Model has a powder paint finish. A hard plastic caster insert is mounted to each leg. Casters are mar-resistant Black hard rubber and 4" in diameter. Each caster assembly has ball bearing swivel capabilities and steel construction. Two (2) have locking brakes. Optional electrical assembly is completely enclosed with two (2) grounded outlets. Includes 20 ft., 3-wire cord and two (2)  $\frac{3}{16}$ " diameter machine screws with wing nuts for attaching unit to the table. Optional electrical assembly is UL Listed when attached. A2642 Adjustable Equipment Table ships assembled in one (1) carton via United Parcel Service (UPS).

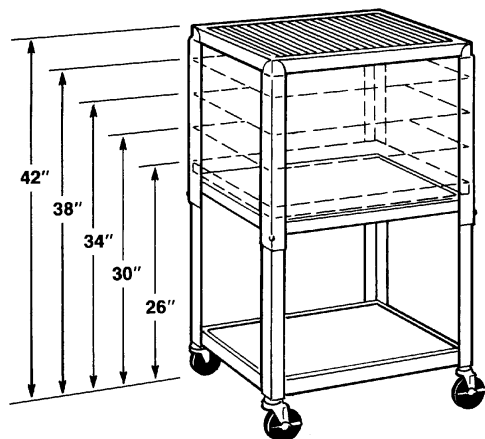

## BRETFORD MANUFACTURING, INC.

11000 Seymour Avenue  
Franklin Park, Illinois 60131 USA  
www.bretford.com

Phone: 847.678.2545  
Fax: 847.678.0852

Toll-Free Fax: 800.343.1779  
Toll-Free Phone: 800.521.9614