

Product Information

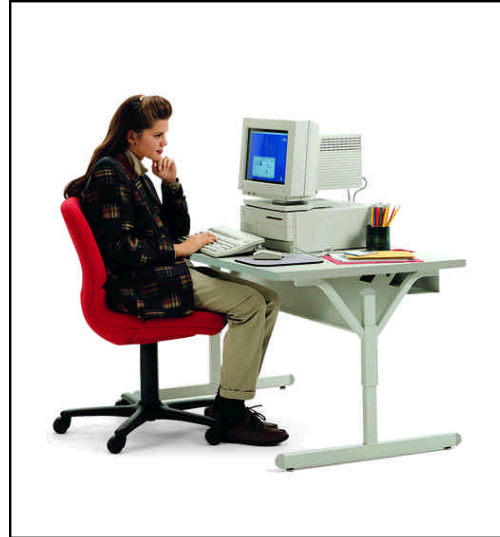

BRETFORD MANUFACTURING, INC.
11000 Seymour Avenue
Franklin Park, Illinois 60131 USA

Phone: 847.678.2545
Toll-Free Phone: 800.521.9614
Fax: 847.678.0852
Toll-Free Fax: 800.343.1779
www.bretford.com



Models 3521-GM_, 3523-GM_, 3524-GM_,
3525-GM_, 3569-GM_, 3570-GM_,
3515-GM_, 3504-GM_, 3561-GM_ & 3565-GM_
Connections Adjustable Work Centers with glides

FEATURES & BENEFITS

- Attractive Grey laminate tabletop trimmed with bullnose edgeband in your choice of four colors
- Large workspace neatly holds two computers side-by-side
- 14-gauge sturdy steel base with a unique "Y" shape design and floor-saving, adjustable glides
- Adjustable in one inch increments from 24" to a 32" high clearance to meet ADA approval
- Modesty panel offers additional leg room and easy accessibility to the power switch
- Cord management bin and grommet holes hide and organize electrical cords
- 36" and 42" W tables have one grommet hole
- 48", 60" and 72" W tables have two grommet holes
- Accessory Low Rise Shelf holds monitor or reference materials
- Optional UL-listed 4-outlet electrical unit with single switch power control

OVERALL DIMENSIONS

- | | | | |
|-------------|--------------------------|-------------|--------------------------|
| • 3521-GM_: | 36" W x 30" D x 24-32" H | • 3515-GM_: | 42" W x 30" D x 24-32" H |
| • 3523-GM_: | 48" W x 30" D x 24-32" H | • 3504-GM_: | 42" W x 24" D x 24-32" H |
| • 3524-GM_: | 60" W x 30" D x 24-32" H | • 3561-GM_: | 60" W x 24" D x 24-32" H |
| • 3525-GM_: | 72" W x 30" D x 24-32" H | • 3565-GM_: | 72" W x 24" D x 24-32" H |
| • 3569-GM_: | 36" W x 24" D x 24-32" H | • 3570-GM_: | 48" W x 24" D x 24-32" H |

COLOR/FINISH

- Base/Tabletops: Grey powder paint/Grey laminate
- Trim, Toe Caps & Grommet Holes: Available in Cardinal (GMC), Topaz (GMT), Polo (GML) and Quartz (GMQ)

Product Specifications

3521-GM_, 3523-GM_, 3524-GM_, 3525-GM_,
3569-GM_, 3570-GM_, 3515-GM_, 3504-GM_,
3561-GM_ & 3565-GM_ CONNECTIONS

ADJUSTABLE WORK CENTER WITH GLIDES

These tables are designed for applications where the work surface needs to be stationary. The Connections Adjustable Work Centers provide maximum user comfort, attractive design, and sturdy construction. Tables feature grommet holes and hinged cord management bins for cords and wires along with integrated modesty panels.

STANDARD EQUIPMENT

Table top (1)
Right leg Assembly (1)
Left leg assembly (1)
Modesty Panel (1)
Cord management bin (1)

ACCESSORIES

3530	36" W Low Rise Shelf
3531	48" W Low Rise Shelf
3532	60" W Low Rise Shelf
3557-GM	Flat Connecting Bracket
3573-GM	Connections Bridge Pack
3574	72" Low Rise Shelf
35CPU1-GM	CPU Holder with Glides
CFPS	Computer Furniture Power Strip
UCSKD-GM	Keyboard drawer
UCSSD-GM	Supply drawer

WEIGHT AND FREIGHT CLASS

Model 3521-GM_: 76 pounds, Freight class 70 UPS.
Model 3523-GM_: 87 pounds, Freight class 70.
Model 3524-GM_: 106 pounds, Freight class 70.
Model 3525-GM_: 107 pounds, Freight class 70.
Model 3569-GM_: 65 pounds, Freight class 70 UPS.
Model 3570-GM_: 74 pounds, Freight class 70.
Model 3515-GM_: 106 pounds, Freight class 70.
Model 3504-GM_: 73 pounds, Freight class 70.
Model 3561-GM_: 105 pounds. Freight class 70
Model 3565-GM_: 111 pounds. Freight class 70.
Ships ready to assemble.

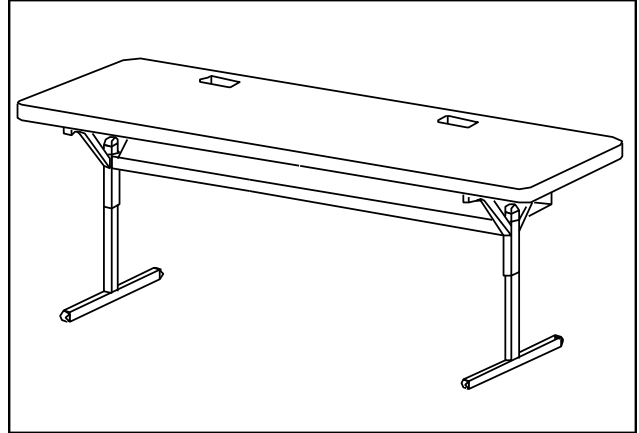

SUGGESTED SPECIFICATIONS

Models 3521-GM_, 3523-GM_, 3524-GM_, 3525-GM_, 3569-GM_ 3570-GM_, 3515-GM_, 3504-GM_, 3561-GM_ & 3565-GM_ are height adjustable from 24-32" in 1" increments. Width is 36" W, 42" W, 48" W, 60" W or 72" W depending on the model. Table top is made from 1" thick laminate particle board, 45-pound density. Cord management bin is constructed from 20 gauge steel and measures 4"H x 5³/₈" D. It runs the width of the table, allowing space for optional shelves to be attached. One side is attached with hinges to the back of the modesty panel, and the other side closes with the choice of a thumb screw or theft proof screw (included) which attaches to the bottom of the work surface. The 3521, 3569, 3515 and 3504 have one grommet hole measuring 1¹/₂" x 4" centered on the work surface. The 3523 and 3570 have two grommet holes located 24" apart. The 3524, 3561, 3565 and 3525 have two grommet holes located 30" apart. On the 3525 and 3565, a 1" square 18-gauge tube connects beneath the surface and runs across the length of the table between leg assemblies. The legs are constructed from 14-gauge steel and are painted with Gray powder paint. Modesty panel is constructed from 18-gauge steel. Model comes with adjustable glides. These models ship ready to assemble in one carton pack.

BRETFORD MANUFACTURING, INC.

11000 Seymour Avenue
Franklin Park, Illinois 60131 USA
800.521.9614

Phone: 847.678.2545
Fax: 847.678.0852

Toll-Free Fax: 800.343.1779
Toll-Free Phone: